

Hi-Res.grade Network Audio Components

f i d a t a

Network Audio Server

fidata

Transporting listeners to the stage or studio where music is born

In the world of high-resolution audio, components must realistically recreate every detail, right down to the performer's breaths, and the atmosphere of the studio or concert hall.

Today, a revolution in audio is making it possible to enjoy the overwhelming presence of original recordings in the comfort of your own home for a reasonable price.



fidata

The ultimate in audio quality, from a brand that lives up to the meaning of its name: “reliability”

Today’s high-resolution audio files deliver quality that approaches that of master recordings by incorporating an enormous amount of data. With the debut of network audio, consumers quickly have become familiar with the immersive experience made possible by that level of quality. Introducing fidata, a family of network audio components that lives up to the meaning of its name: “reliability.”

Welcome to the world of ultimate sound.



Models	3
Functionality	4
Network audio	5
Server functionality	7
USB DAC player functionality	9
CD ripping and playback	10
HFA51-XS20U	12
Chassis/Storage	14
Circuit design	15
Power supplies	17

An audio server engineered for use in high-end systems

The fidata HFAS1 is a network audio server that was engineered so that you can enjoy high-end audio. You can see evidence of our meticulous, iterative approach from the materials chosen for the chassis to the design of the unit's circuit board and its individual components. This product is the cumulative result of numerous prototypes and countless trial listening sessions. The result is an exceptional level of audio quality that befits the unit's high-end name, packaged in an impressive chassis from which every hint of waste has been pared.

HFAS1-XS20U <models with X-Cluster SSDs> ———— MADE IN JAPAN  



2.0 TB SSD (striped)
*Effective capacity: 2 TB
(Silver)

For more information about the HFAS1-X series, see pages 12 and 13. ↘

HFAS1-S10U ———— MADE IN JAPAN   



1.0TB SSD (Spanning)
*Effective capacity: 1 TB
(Silver)

*RAID setup is user-configurable.

The HFAS1 delivers a total solution for experiencing music digitally.

The HFAS1 is a one-stop digital audio solution that delivers an audio-quality media server, USB DAC compatibility (network transport), CD ripping, and CD transport functionality in addition to capabilities ranging from music import and playback to data protection. By giving you the freedom to combine components as desired, HFAS1 makes it possible to create an audio system that reflects your own individuality.

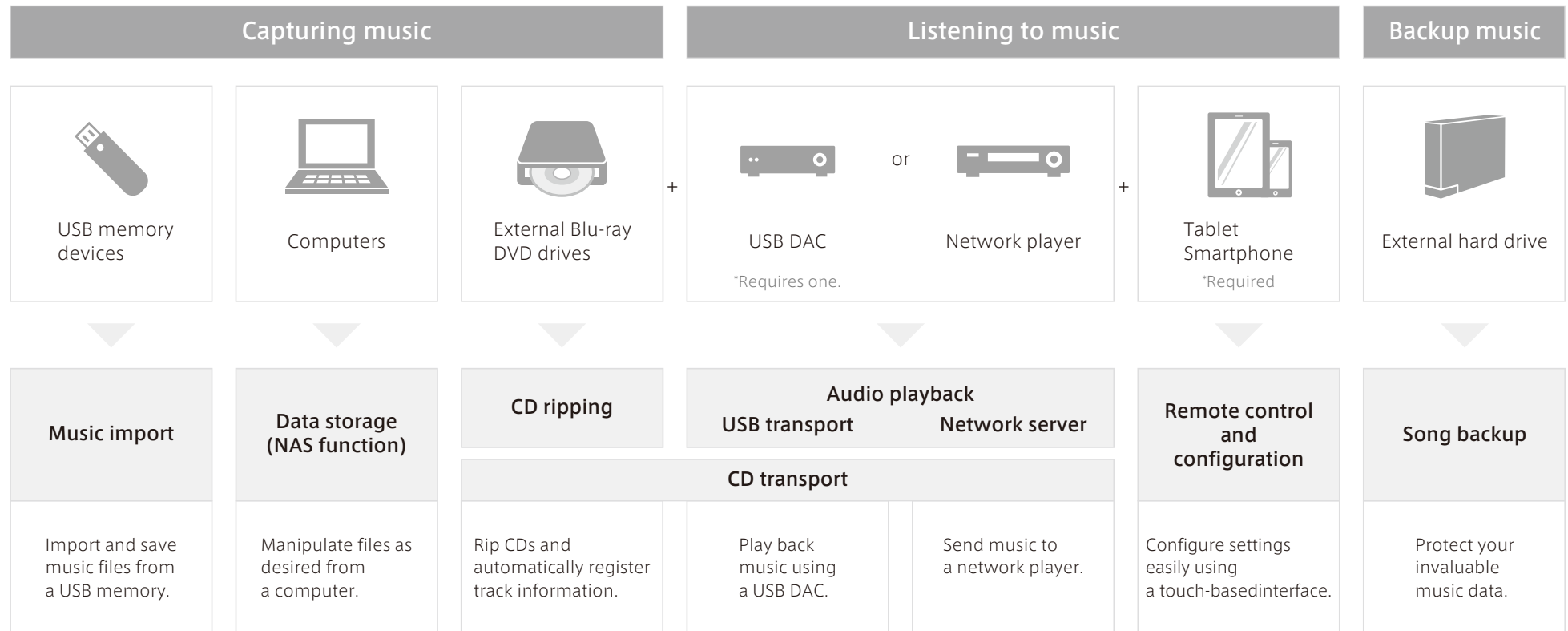

Network audio: A new listening style

Anyone can now download high-resolution audio files with the ultimate level of quality from the Internet. With the debut of such files, we have moved into an era of “media-less” playback in which it is possible to download high-data rate music that has been freed from the recording capacity constraints of physical media such as CDs, store it on computer hard disks, and listen to it using dedicated players.

The shortcoming of this playback method is its interposition of a computer into the audio system. Computers pose a variety of issues for audio purists, ranging from difficult connections and settings to complex operation and intractable noise issues.

These problems were resolved with the advent of network audio components that play audio directly from hard disks that are connected to networks (network-attached storage, or NAS). Under this paradigm, audio files are stored in a library on an NAS device, and mobile handsets such as smartphones are used as controllers to intuitively download, manage, and play the files. In this way, network audio has exceeded the CD in terms of ease of use.

Add a network player of your choice: Media server function

Instead of a rack of CDs, listeners can manage enormous libraries of audio file assets based on artist, album, genre, and other attributes using a software application (known as a media server). The fidata HFAS1 delivers the ultimate in network audio.

Combine the fidata with a DLNA- or UPnP-compliant network player of your choice. Built-in Twonky Server software provides advanced functionality.

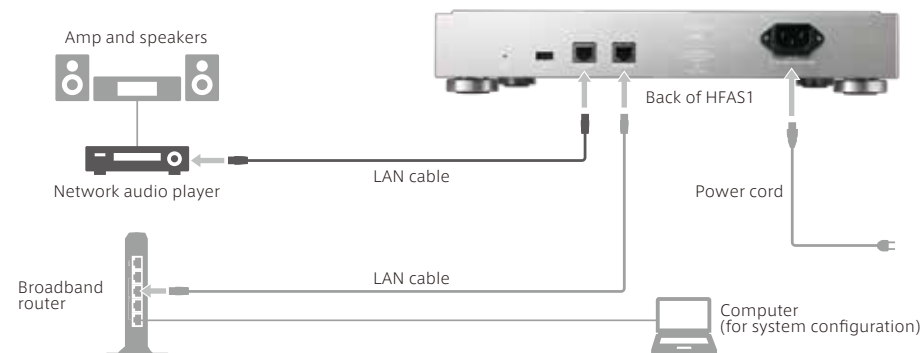

Combine with a USB DAC and use as a network player.

You can use the HFA51 as a PCM/DSD-compatible network audio player with a built-in server by connecting it to an audio device with a USB DAC (for example, a standalone unit, CD player amp, or headphone amp). In this configuration, you can choose tracks and control playback from a DLNA- or OpenHome Media-compliant controller app on a smartphone or tablet. Build the system that's right for you by picking a DAC to handle the sound and a controller to handle the user interface... now there are even more possibilities for enjoying your music.



Get the sound you're after by choosing the USB DAC you want!

The HFA51 can be combined with any of a number of USB Audio Class 2.0-compliant USB DACs whose compatibility has been confirmed. Since you can choose a DAC that has the sound characteristics you like, you can build a unique network audio system that suits your own usage environment.

Using existing devices to deliver network audio

By adding the HFA51 to their setups, listeners who have been wavering over whether to buy a high-grade network audio player can enjoy network audio while using the USB DAC they already have. With robust server and playback functionality at a reasonable price, the HFA51 is the ideal choice for listeners who are looking into the world of high-resolution audio for the first time.

High-quality audio data output, even over a USB connection

USB DACs are typically used with ordinary computers, which aren't generally designed from an audio perspective, so listeners may not be able to enjoy the full benefit of the DAC's capabilities. Since it's designed as an audio device, the HFA51 delivers high-quality data output, including from its USB port. The unit taps the latent capability of USB DACs, without difficult settings.

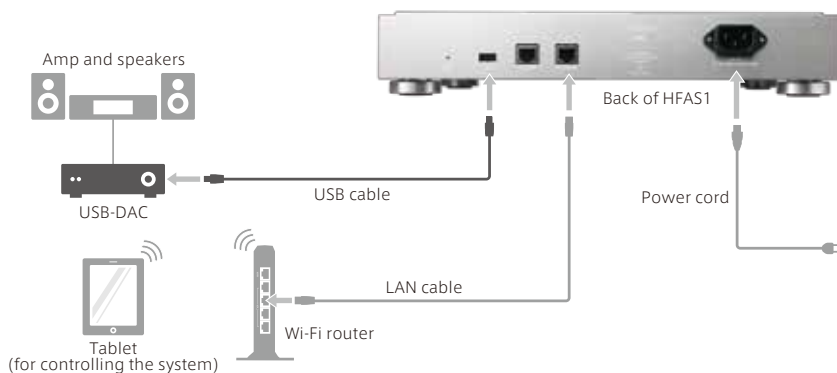

Example of USB DAC device support

Standalone USB DAC



Combine the HFA51 with a standalone USB DAC and use it as a network player.

CD player with a USB DAC



Combine the HFA51 with a CD player that has a USB DAC and use it as a CD and network player.

Headphone amp with a USB DAC



The HFA51 is ideal for listeners who prefer headphones. Use a smartphone or tablet to choose tracks and control playback.

A truly intuitive interface designed specifically for audiophiles

DLNA certified

The Digital Living Network Alliance (DLNA) has formulated a series of guidelines to simplify audio and video playback using audiovisual components as well as computers, smartphones, tablets, and other network-connected devices from various manufacturers. Music files stored on the HFAS1 can be played back on multiple DLNA-compliant devices connected to users' wireless and wired networks. For example, a user could enjoy music stored on an HFAS1 in the living room on a network audio player in another room.

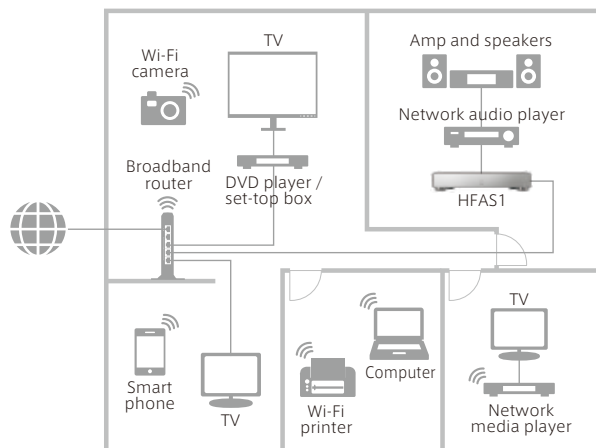

Customized Twonky Server for enhanced ease of use

The HFAS1 uses Twonky Server, the de facto standard for music management, transmission, and distribution. The software is highly compatible with various manufacturers' network players and known for its ease of use. Twonky Server's extensive functionality includes a navigation tree function that facilitates fine-grained sorting of large numbers of music files as well as the ability to display high-resolution album art. The HFAS1's version of the server has been customized to properly display song and artist names and to display songs and album tracks in the proper order. The software delivers a level of ease of use and scalability that were unthinkable during the age of disc media such as CDs.

Twonky Server: A media server that provides various methods for searching for songs



Extensive selection of categories so you can easily find the songs you're looking for

- Folder
- Recently added
- Artist
- Artist index
- Album
- Album index
- Composer
- Format
- Date
- Artist/album
- Genre/album
- Genre/artist/album
- Genre/song
- Playlist
- Personal rating
- All music
- Title index

Display of high-resolution album art in the standard configuration

The HFAS1's implementation of Twonky Server is designed for use in audio applications and comes configured to distribute high-resolution album art in its standard configuration. Users can enjoy beautiful album art on supported devices whose compatibility has been confirmed without needing to make any difficult settings.

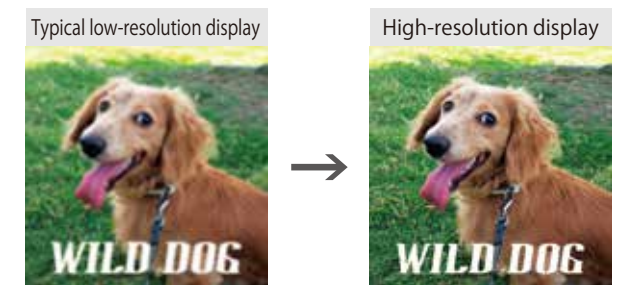



Support for DSD files as well as WAV and FLAC

In addition to PCM (wav) and FLAC (flac) files at up to 32 bits and 768 kHz, the fidata now supports DSD (dff/dsf) format files at up to 11.2 MHz.

Simple and smart: Setup that's easy for everyone

To set up the HFAS1, you need only connect it to a network audio player and router with LAN cables. Additional settings can be configured on a computer, tablet, or smartphone using the Magical Finder management software, which allows users to access setup screens simply by selecting devices in response to dialog-style prompts.

Power-based switchless on/off

Since the HFAS1 releases system cache data to the drives as necessary, it can be turned off simply by cutting off its AC power supply without corrupting system or audio data, as long as data isn't being written when it is turned off. The unit can be turned off by cutting off its power supply in the same manner as other audio devices.

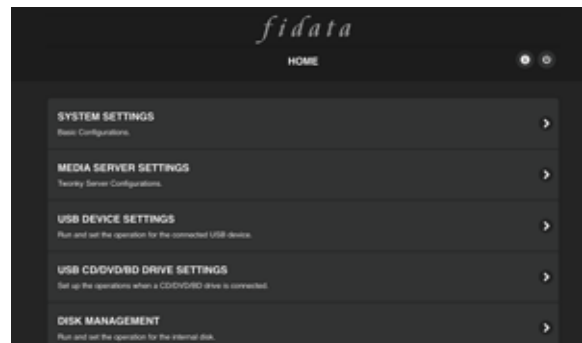

Introducing OpenHome Media support!

The fidata USB DAC player delivers exceptional usability.

USB Audio Class 2.0 support

Simply connect a standard USB Audio Class 2.0-compliant USB DAC to the HFAS1's USB port. The unit will automatically recognize the DAC, allowing the HFAS1 to function as a network audio player.

*See I-O DATA's website for a list of models whose compatibility has been confirmed.

Network renderer function

The HFAS1 provides two playback modes (OpenHome and DMR) from which the user can select on the setup screen.

•OpenHome mode

This mode allows use of OpenHome Media-compliant controller apps.

•DMR mode

This mode allows use of DLNA-compatible digital media controller (DMC) apps.

PCM output

The HFAS1 can output 16-bit/24-bit and 32-bit float/integer PCM data at a maximum sampling rate of 384 kHz, enabling it to output WAV, AIFF, FLAC, and M4A (Apple Lossless) audio data without degradation.

*Playback performance depends on the USB DAC used.

DSD output

The HFAS1 supports native DSD output using DoP (DSD Audio over PCM Frames), allowing it to generate 2.8 MHz, 5.6 MHz, and 11.2 MHz DSD output. This capability allows the unit to output DSD audio data (in both DSF and DFF formats) without degradation.

*Playback performance depends on the USB DAC used.

On-device playlists

In OpenHome mode, on-device playlist support allows playlists to be saved on the HFAS1. Even if the controller app is exited during playback, the HFAS1 will continue playback based on the playlist.

Gapless playback

When used with a compatible application, the HFAS1 supports gapless playback, allowing natural playback of live recordings and other audio recorded without gaps between tracks.

*Supported file formats: wav, aiff, m4a (alac), flac, dsf, and dff.

*Gapless playback is limited to tracks of the same file format, bit depth, and sampling rate.

*Gapless playback is not supported for 11.2 MHz DSD files (as of March 2016).



The kind of high-precision CD ripping you expect from a high-end system and CD transport function as only network audio can provide

fidata CD ripping

The fidata's CD ripping function allows you to rip music CDs to the HFAS1 without a computer. Simply connect an external USB DVD/Blu-ray drive to the fidata. The fidata's meticulously designed CD ripping function combines the convenience of being able to automatically acquire track information and album art with the press of a single button with bit-perfect ripping performance.

- Start ripping quickly and easily by simply pressing the button on the fidata (automatic configuration of the ripping process is also supported).
- Save data as either WAV or FLAC files in the PCM format (44.1 kHz/16 bits).
- When using the FLAC format, choose from three compression levels, including an uncompressed option.
- Track information and album art are automatically acquired from the Gracenote® Music ID® service.
- The fidata works with the AccurateRip™ track data comparison database to ensure every copy is bit-perfect.
- If verification fails, the fidata will try again automatically after changing the ripping settings.
- Once ripping completes, the disc is automatically ejected from the DVD/Blu-ray drive.

*An Internet connection is required in order to use Gracenote® Music ID® and AccurateRip™.
*The AccurateRip™ service utilized by this product accesses CD ripping data provided by the UK company Illustrate Limited. This service is subject to termination in the future without notice. In the event the service is terminated, all aspects of the CD ripping function other than access to AccurateRip™ will continue to function as before.

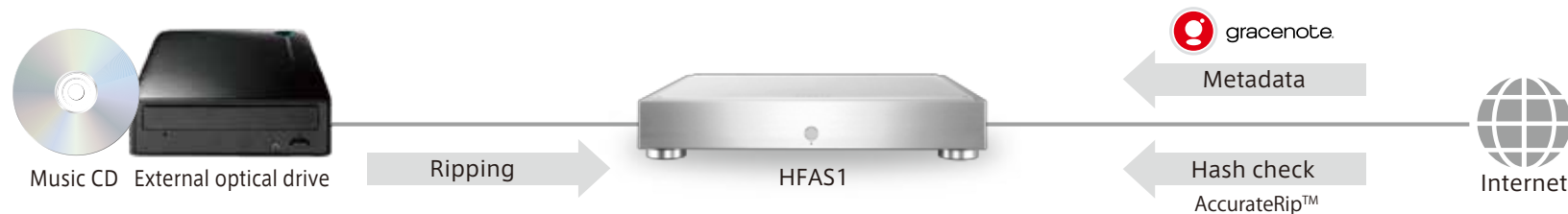

fidata CD transport

The fidata CD transport function lets you share music CDs over the network so that they can be played directly by other connected devices. By combining track information and album art acquired from the Gracenote® Music ID® service with a music CD that has been loaded into a USB-connected DVD/Blu-ray drive and sending the data over the network, the fidata lets you enjoy listening to the CD on a supported USB DAC or network audio player.

- The CD will show up as "#CD: Album title" under "Folders" in the media tree.
- Music CDs can be played via either a USB DAC connection¹ or a network player connection.
- A USB hub is required in order to play a music CD via a USB DAC connection.
- You can choose tracks on the music CD by name rather than number.
- You can control music CD playback using the control app or other means, just as with network audio.

¹ An Internet connection is required in order to use Gracenote® Music ID® and AccurateRip™.
*An Internet connection is required in order to display track titles (via the Gracenote® Music ID® service).





An uncompromising dedication to quality on par with the best in network audio

Take the chassis, for example.

The austere exterior, from which all traces of ornamentation—even a display—have been excised, represents an inevitable form that has reached the limits that come from a single-minded drive to recreate ideal sound. In each capacitor, in the circuit board layout: everywhere you look, you'll find thoughtful dedication to details. This is a network audio server that's not afraid to call itself high-end.

More storage capacity for even greater utility and performance

One year after the HFA51's debut: Introducing a high-end model sporting the "X" moniker

The HFA51-XS20U builds on the basic design of the popular HFA51-S10U by adding an X-Cluster SSD unit designed specifically to deliver high 2 TB storage capacity and the high level of quality required by audio applications. This high-end fidata network audio server also utilizes a steel chassis that's 3.2 mm thick for significantly higher rigidity so that it can deliver an even higher level of performance.

*Apart from the X-Cluster SSD, the HFA51-XS20U shares its circuit design and software with the HFA51-S10U.

X-Cluster SSD unit designed specifically for audio applications

Instead of simply utilizing a single, large SSD, fidata incorporates a new technology known as X-Cluster Storage Technology to deliver high storage capacity along with the high quality required of audio components.

Dedicated X-Cluster SSD unit for audio

The X-Cluster SSD was developed specifically for the HFA51-XS20U. This cluster stripes data uniformly across two SSDs. The resulting ability to access data uniformly across all SSDs in the cluster smooths the load on the power supply load by limiting deviations in power consumption. In addition, the HFA51-XS20U features a pair of dedicated linear power conditioners that provide clean power.



X-Cluster Storage Technology

Designers of audio devices must exercise maximum care with regard to power supplies. Featured in the HFA51-XS20U, X-Cluster Storage Technology is a new, proprietary fidata technology developed from an audio storage perspective to deliver high SSD storage capacity, a more stable power supply, and reduced noise.

A cluster of four SSDs

The HFA51-XS20U incorporates two X-Cluster SSD units, one on the left and one on the right, for a total of four SSDs. The result is an enormous 2 TB cluster of storage configured in a way that reduces power supply fluctuations caused by uneven data access.



*Specifications other than those indicated here are the same as the HFA51-S10U.

Linear power conditioners

In addition to the HFA51's power supply circuit, which consists of a dedicated switching power supply for the storage subsystem and a dedicated power generation circuit that has been tuned with numerous capacitors, the HFA51-XS20U adds a pair of linear power conditioners for its X-Cluster SSD units. This design contributes greatly to more stable power supply performance.

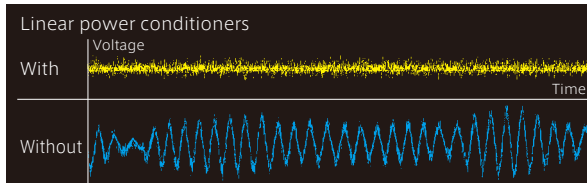

Significantly increased rigidity thanks to a steel chassis that's 3.2 mm thick

The HFA51-XS20U uses a steel plate that is 3.2 mm thick to increase its chassis rigidity. We revisited both the material and the surface finish of the base steel plate, which is 1.4 times thicker than the previous design. The new model's hot-rolled steel features a black chromate finish, preserving the fidata's well-received appearance while maximizing its chassis rigidity.



Comparison HFA51-XS20U and HFA51-S10U

	HFA51-XS20U	HFA51-S10U
Storage capacity	2.0 TB	1.0 TB
SSD capacity and quantity	500 GB × 4	500 GB × 2
X-Cluster Storage Technology	Yes	No
X-Cluster SSD	Yes (2)	No
Linear power conditioners	Yes (2)	No
Base steel plate	3.2 mm thick (fabricated from 3 kg hot-rolled steel)	2.3 mm thick (fabricated from 2 kg cold-rolled steel)
fidata CD ripping	Yes	Yes
fidata CD transport	Yes	Yes
Maximum power consumption	Rated for 32 W	Rated for 25 W
Weight	Approx. 7.3 kg	Approx. 6 kg

Aggressively counteracting vibration and noise

High-rigidity, all-metal chassis

The fidata combines thick, aluminum E-shaped side panels with a 4.0 mm thick aluminum top. A high-rigidity steel base provides stability in the face of vibration. Inside the chassis, a T-shaped arrangement of steel members divides the space into two areas, one for the power supplies and circuit board and another for the storage subsystem, limiting radiation noise from the latter and minimizing any effects on the former.



4.0 mm thick aluminum top cover

Machined aluminum insulators

The HFAS1 uses proprietary insulators to support the heavy chassis, which can be reconfigured from four to three supports as desired.



Four-support configuration



Three-support configuration

Dual SSDs (HFAS1-S10U)

The HFAS1-S10U incorporates two 850EVO high-reliability SSDs from Samsung. These drives utilize the manufacturer's 3D V-NAND flash memory to minimize voltage fluctuations through extended durability and reduced power consumption. Other design features such as an aluminum enclosure with excellent anti-noise characteristics give the 850EVO characteristics that are exceptionally well suited to audio applications. Additionally, use of flash storage without any moving parts makes it possible to deliver an almost silent listening environment.

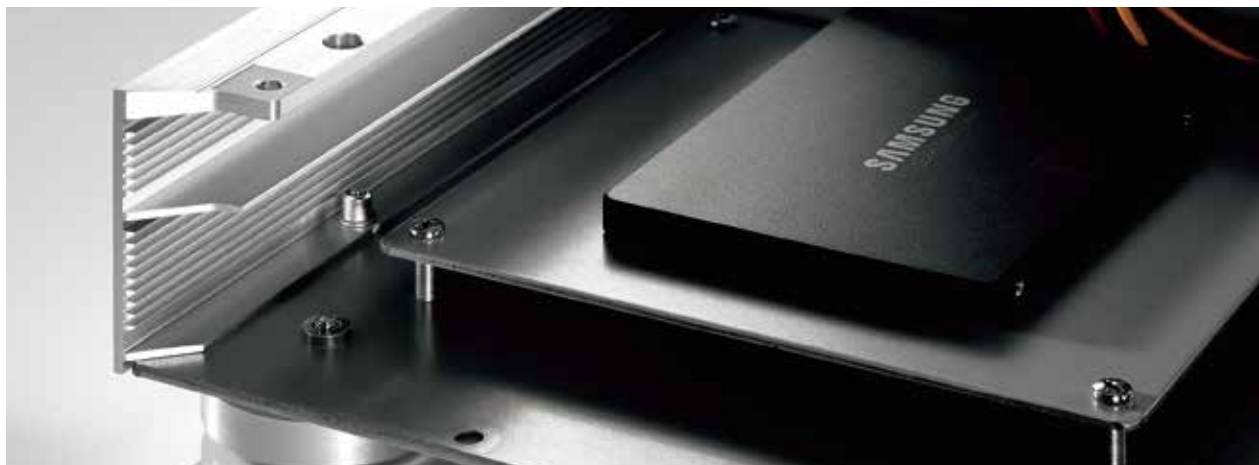

An uncompromising circuit design focused on minimizing noise and maximizing transmission quality through extensive use of high-grade parts

Two independent circuit blocks

The circuits that power the main circuit board's system hardware and its storage devices are completely isolated to keep power supply noise from the latter from adversely affecting the former. In this way, we have aggressively eliminated the effects on system circuitry of noise generated during drive access.

Single-point ground to prevent noise generation, leakage, and introduction

Counteracting noise is the single greatest issue in the design of audio devices. The HFA51 features an optimized pattern design and a single-point ground configuration that grounds circuitry via a single connection to the unit's copper base. This arrangement allows it to generate an exceptionally stable supply of power from which common impedance has been eliminated.

High-capacity electrolytic capacitors

The HFA51's circuit board incorporates an optimal arrangement of low-ESR electrolytic capacitors that includes some audio-grade components. This design implements a high-quality, stable power supply.

25 MHz low-phase-noise crystal oscillator

The HFA51 uses a vacuum-type crystal oscillator with low phase-noise characteristics. In addition to limiting clock jitter, this design implements high-precision network transmission using a clock generated by a high-precision crystal.

Link separation system

The HFA51 provides two LAN ports, one for audio and one for networking. The "for Audio" port is designed to be connected to a network audio player, while its "for Network" counterpart is designed to be connected to the user's home network, enabling the high-quality signal generated by the unit to be transmitted directly to the player.

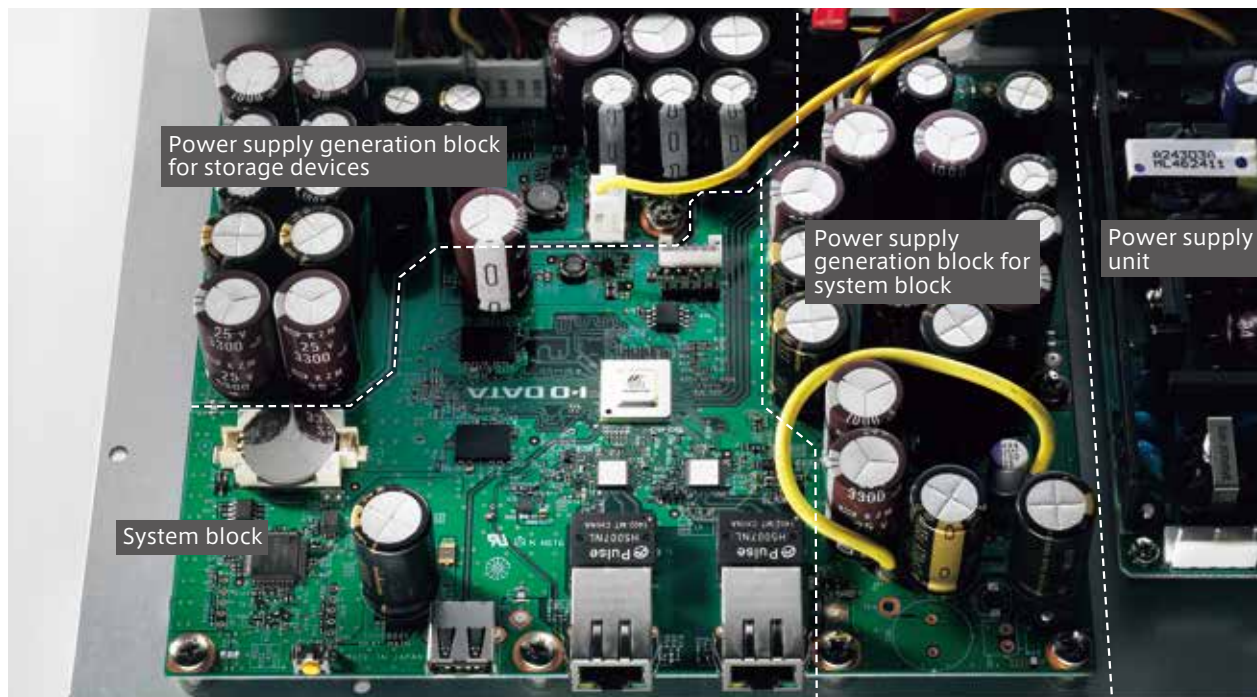

LAN connectors with exceptional contact performance

The two LAN connectors have been oriented with the signal terminals at the top in order to ensure stable contact with the LAN cables' terminals. In addition, the DIP-type LAN connectors used by the HFAS1 each feature a mechanically robust, 14-point connection to the circuit board. This design prevents the connector and terminals from becoming misaligned in order to preclude any adverse effects from vibration.

LED-off function to counteract noise

The two LAN ports incorporate LED lamps that flash or illuminate continuously to indicate information such as the connection status and communications speed between the HFAS1 and other audio devices and the router. However, users can disable these lamps on the setup screen in order to minimize any noise resulting from their operation.



USB 2.0 connector chosen from an audiophile perspective

The incorporation of audio-grade electrolytic capacitors into the power supply line limits the power supply noise that occurs between devices when a USB DAC or USB drive is connected to the system, delivering exceptional signal transmission quality.





Two power units supply clean, stable power.

Dual high-quality, high-reliability 50 W switching power supplies

Power supply design plays a major role in facilitating high-quality audio playback. The fidata features two 50 W TDK-Lambda power supplies (for a total of 100 W), one to power the main circuitry and the other to power the drives. Independent system and storage power supplies serve to limit noise.



Operating environment

Computers

Supported operating systems	Windows 10 (32-/64-bit) Windows 8.1 (32-/64-bit) Windows 8 (32-/64-bit) Windows 7 (32-/64-bit) OS X 10.7 to 10.11, macOS 10.12
-----------------------------	--

Supported browsers	Internet Explorer 9/10/11 Microsoft Edge 25 Safari 6/7/8/9/10
--------------------	---

Smartphones

Supported operating systems	iOS 7.0.4 ~ 10.0.2 Android 4.1 ~ 7.0
-----------------------------	---

Supported browsers	As embedded in the operating system
--------------------	-------------------------------------

File formats supported by the media server supported file formats (extensions)

wav, mp3, wma, m4a, m4b, ogg, flac, aac, mp2, ac3, mpa, aif, aiff, dff, dsf

USB DAC supported file formats (extensions)

wav, aiff, aif, m4a, flac, dff, dsf, mp3, aac, ogg

USB DAC output formats (sampling rates)

PCM format (44.1 kHz, 48 kHz, 88.2 kHz, 96 kHz, 176.4 kHz, 192 kHz, 352.8 kHz, 384 kHz, 705.6 kHz, 768 kHz)
DSD format (DoP) (2.8 MHz, 5.6 MHz, 11.2 MHz)

USB DAC output formats (bit depth)

PCM format (16-bit, 24-bit, 32-bit), DSD format (DoP) (1-bit)

View a list of supported devices here.



Hardware specifications

LAN interface	Transmission standards	1000BASE-T/100BASE-TX/10BASE-T
	Connectors	RJ-45 × 2 (Auto MDI/MDI-X compatible)
USB ports	Connectors	USB2.0 x1
Networking	Standard compliance	UPnP AV, DLNA 1.5
Supply voltage		AC100V-240V 50/60Hz
Power connector		3-pin inlet
Power consumption	HFA51-XS20U	Rated for 32W
	HFA51-S10U	Rated for 25W
External dimensions (excluding protruding parts)	HFA51-XS20U	Approx. 350 (W) × 350 (D) × 65 (H) mm
	HFA51-S10U	Approx. 350 (W) × 350 (D) × 64 (H) mm
Weight	HFA51-XS20U	Approx. 7.3 kg
	HFA51-S10U	Approx. 6 kg
Operating temperature range		5°C to 35°C
Operating humidity range		20% to 85% (non-condensing)
Accessories		Power cords (3 types), user manual
Product warranty		2 year from date of purchase

fidata website: <http://www.iodata.jp/fidata/>



I-O DATA DEVICE, INC.

- Company and product names are generally the trademarks or registered trademarks of their respective owners.
- The color of the product may differ slightly from depictions in this catalog due to discrepancies introduced during photographing and printing processes.
- Information in this catalog is current as of April 2017. Product design, specifications, appearance, and pricing are subject to change without notice.
- For the latest product information, please see the product website.
- Inquiries are only accepted in English.

I-O DATA